

Surfer

Created /2008

Difficulty / Intermediate

Time to Create / 1 hour

Dimension / R= 0.5 for height

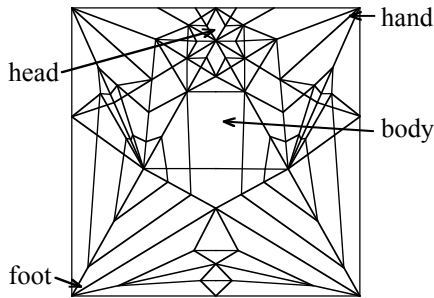

Author's advice: Finally, you can fold the ultimate predator at play. Use paper with a skin color on one side, and a wet suit color on the other side (black, gray, or blue).

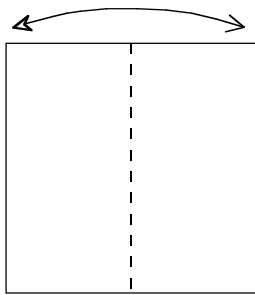

1. Valley-crease the midline.

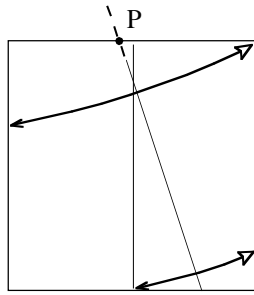

2. Put the top right corner on the left edge and the right edge to the middle of the bottom edge. Crease the top edge only at point P.

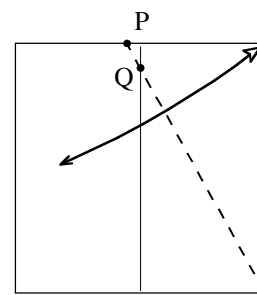

3. Valley-fold and unfold from the bottom right corner to point P. The intersection of this fold with the midline is point Q.

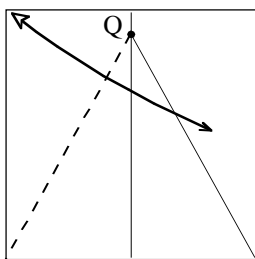

4. Valley-fold and unfold from point Q to the bottom left corner.

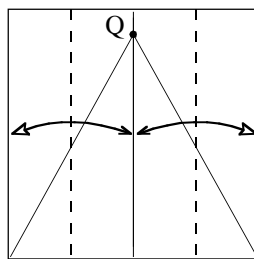

5. Valley-fold and unfold the sides to the midline.

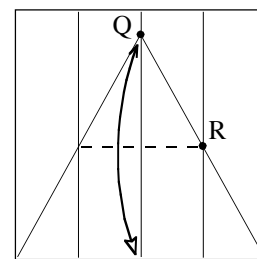

6. Valley-fold and unfold the bottom edge to point Q. Crease where indicated. The right side of the crease is point R.

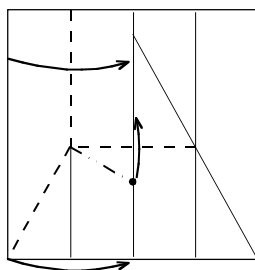

7. Bring the bottom and top corners to the midline and stretch the paper at the dot up as far as it will go. The model will not lie flat.

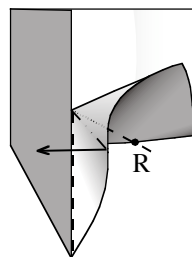

8. Bring the bottom edge to the left while valley-folding through point R.

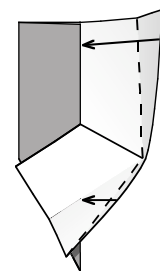

9. Valley-fold the right edge to the midline.



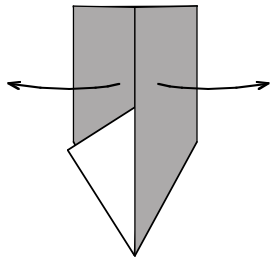

10. Unfold the model.

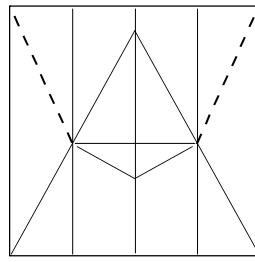

11. Valley-crease.

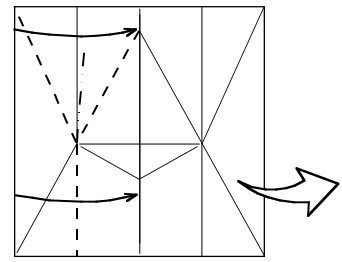

12. Inside reverse-fold the top of the model so that the left side lies along the midline.

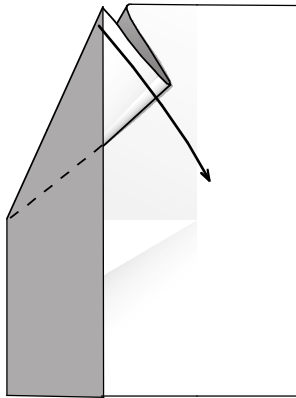

13. Valley-fold the flap down.

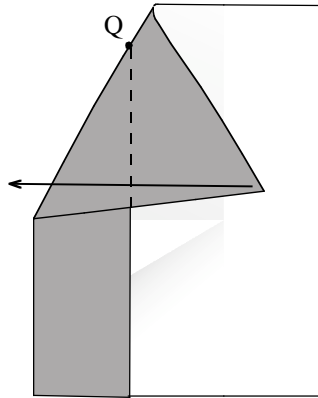

14. Valley-fold the flap to the left. The fold lies along the midline.

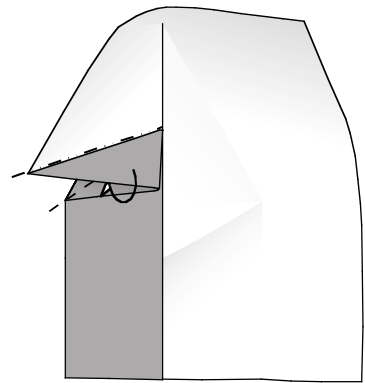

15. Inside reverse-fold.

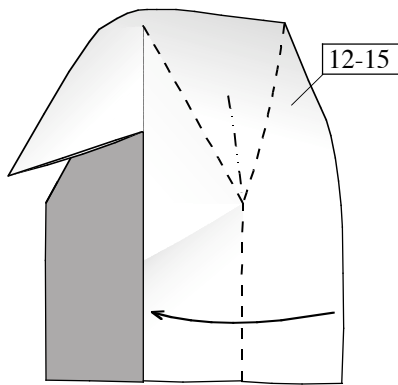

16. Repeat steps 12 to 15 on the right side.

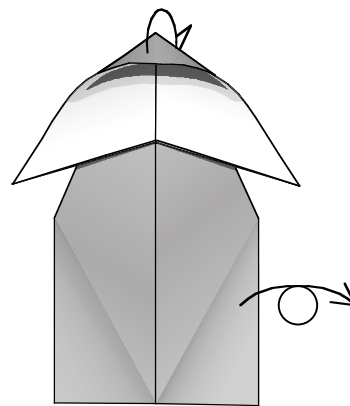

17. Wrap the top edge to the other side. Turn the model over.

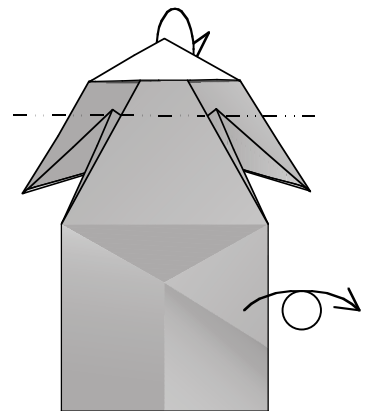

18. Mountain-fold the head down. Turn the model over.

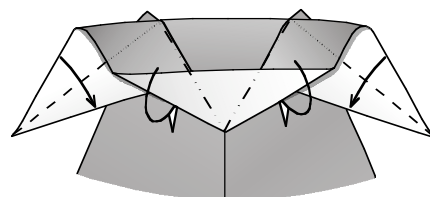
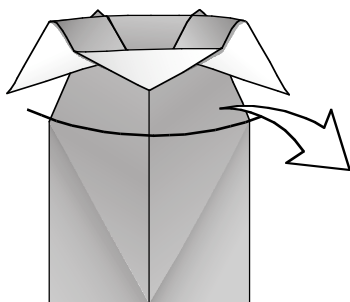

19. Swivel-fold.

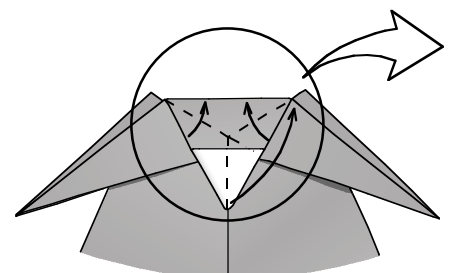

20. Rabbit-ear fold the head.



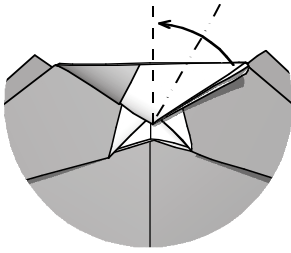

21. Squash-fold the head.

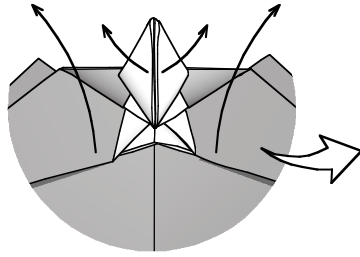

22. Spread the paper of the head and arms.

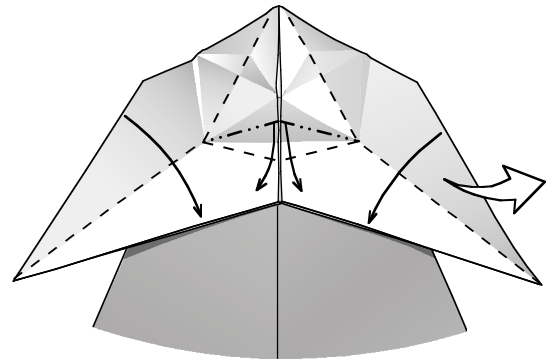

23. Redo steps 20 to 21 with the additional crimps in the top layer in the center. Mountain folds are angle bisectors of the shaded triangle.

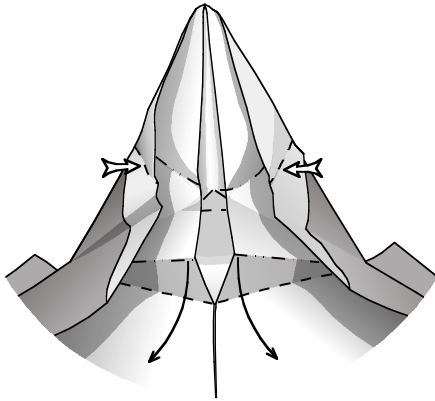

Step 23 in progress.

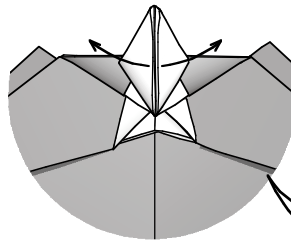

24. Spread apart two layers on each side of the head.

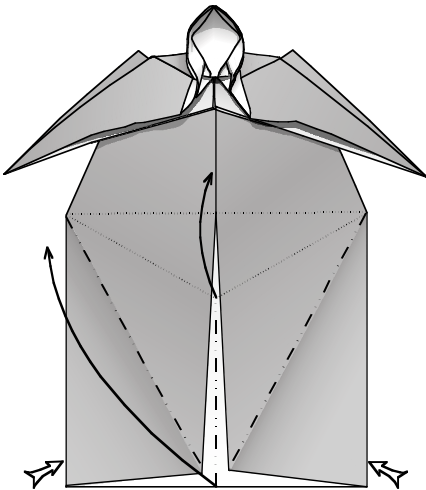
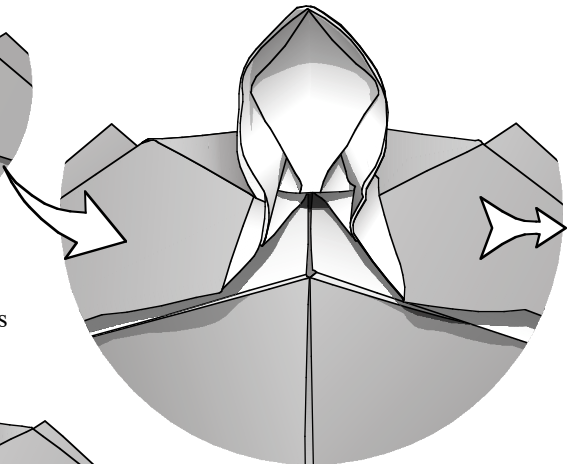

25. Redo steps 7 and 8 on the bottom half.

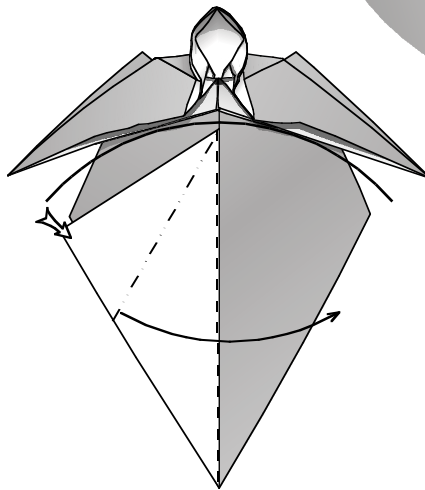

26. Squash-fold.

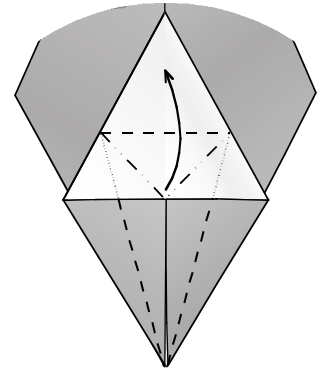

27. Petal-fold.

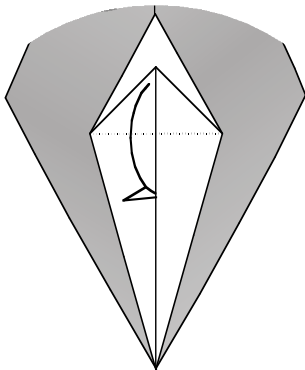

28. Put the peak inside.

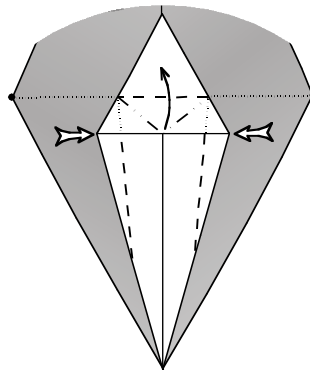

29. Narrow with a squash petal fold. The horizontal valley fold is in line with the corners marked by dots.

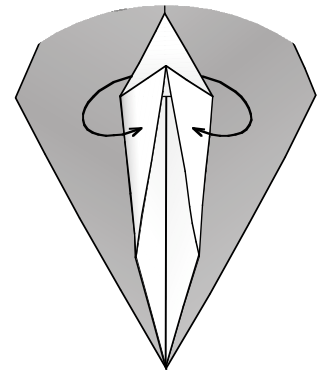

30. Put a layer on top.



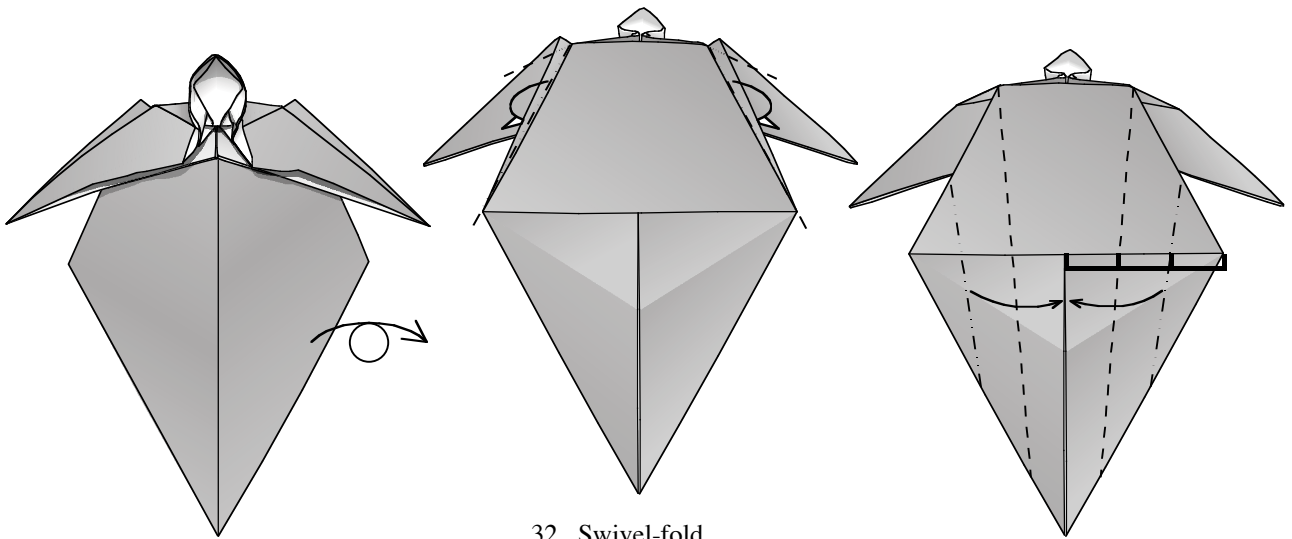

31. Turn the model over.

32. Swivel-fold.

33. Pleat sides.

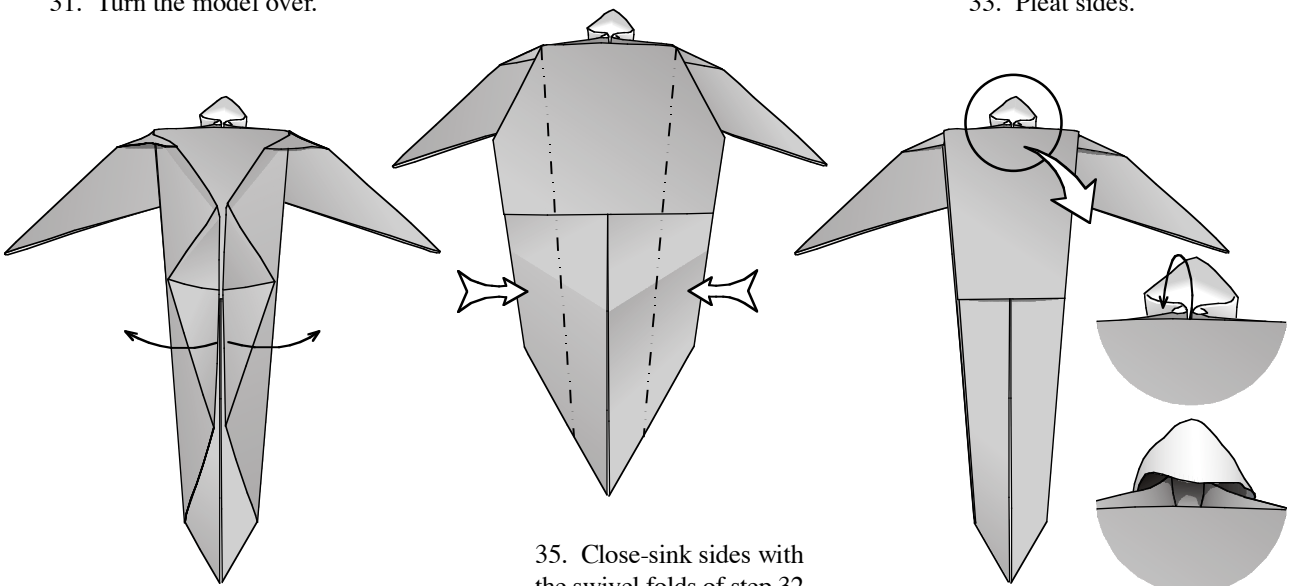

34. Unfold one pleat on each side..

35. Close-sink sides with the swivel folds of step 32 in place.

36. Partially open the head folds to release the raw paper edge.

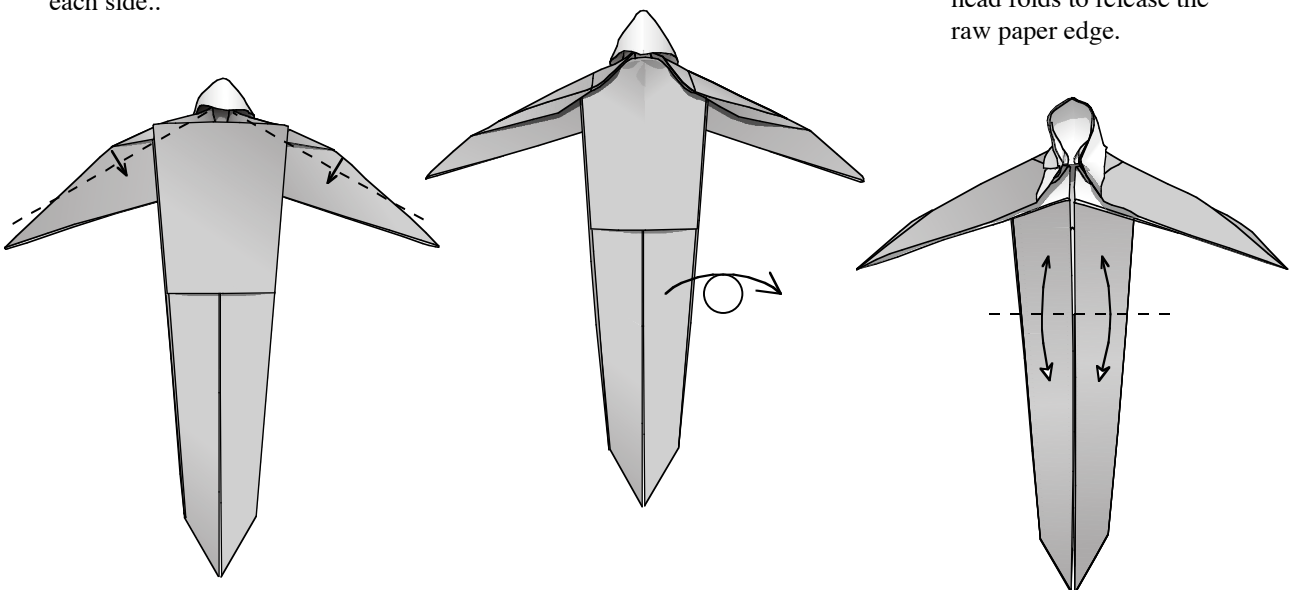

37. Valley-fold shoulders and arms.

38. Turn the model over.

39. Lift the legs up and down where they join the body.



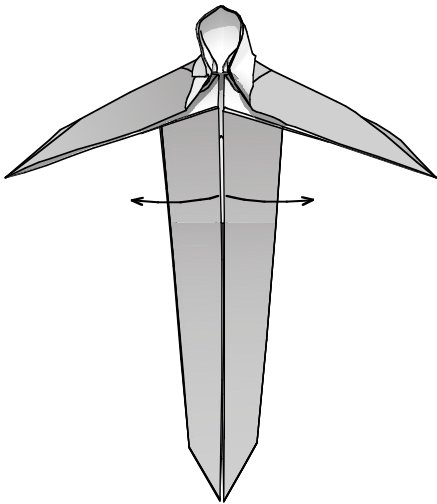

40. Open the body cavity.

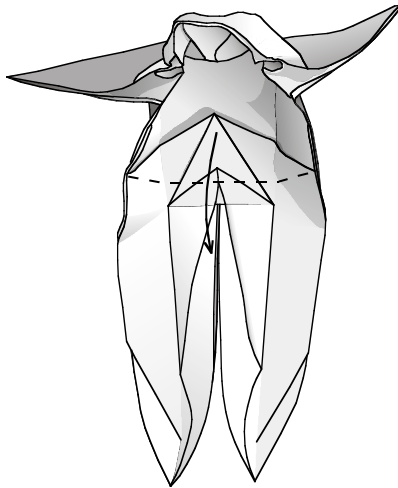

41. Valley-fold the peak down.



42. Close the body cavity.

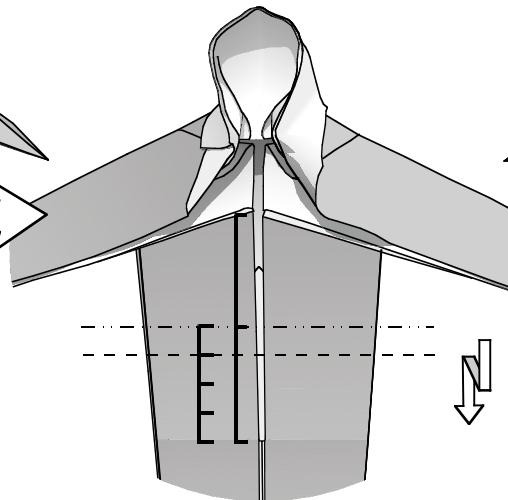
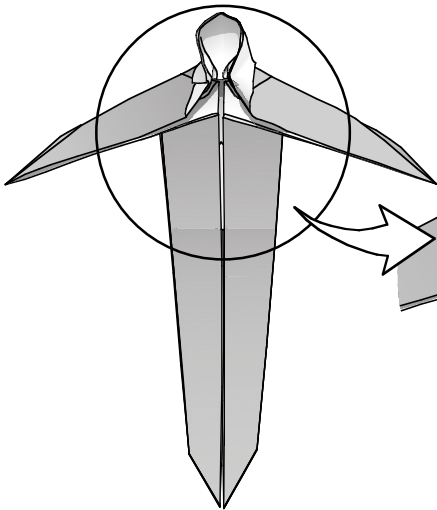

43. Pleat through all layers

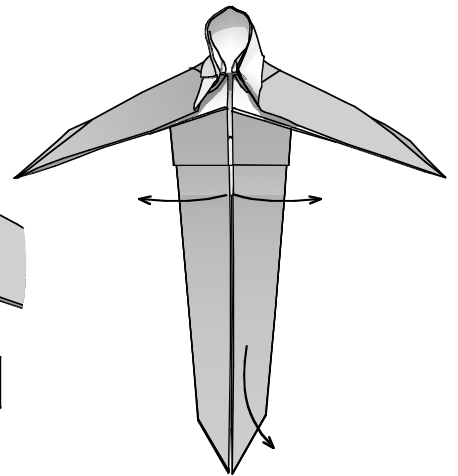

44. Undo the pleat and open the body cavity.

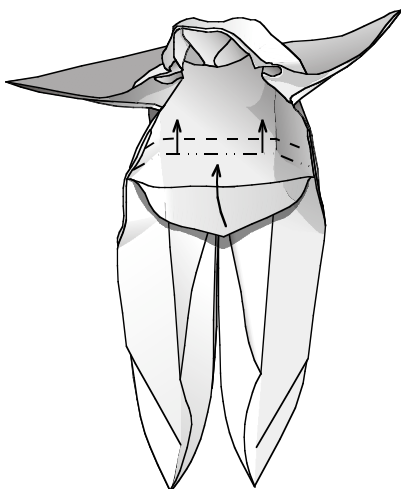

45. Pleat the body symmetrically and then fold the peak back up.

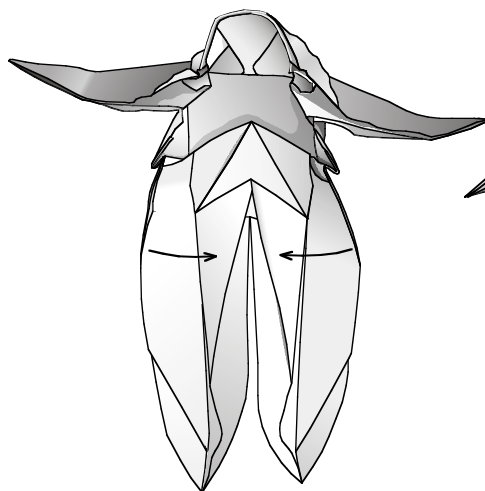

46. Close the body.

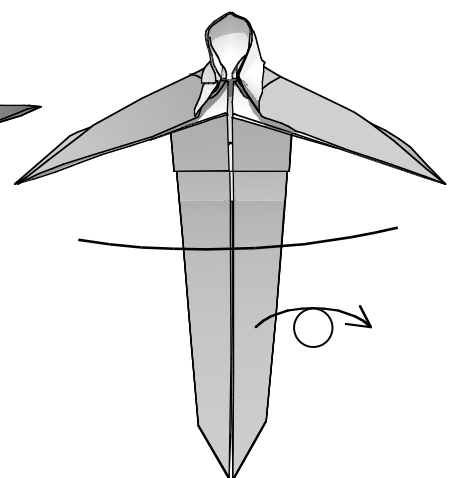

47. Turn the model over.



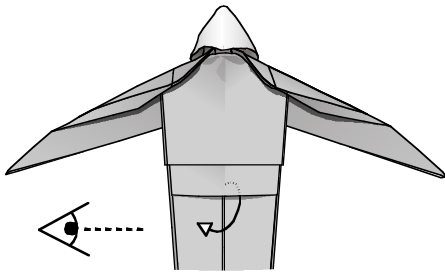

48. Push out some paper to round the rear. This will bend the waist and add more 3 D to your surfer.

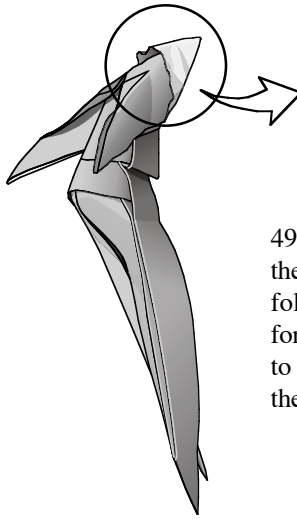

49. Push the face out from the back of the head. Valley-fold the peak down on the forehead and separate layers to form hair on the sides of the head.

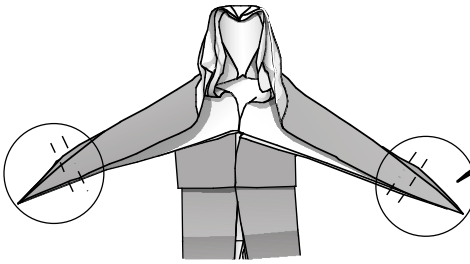
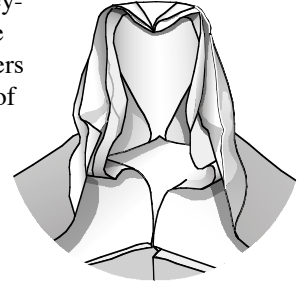
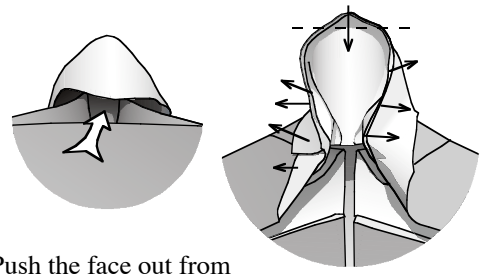

Do the following steps on both hands.

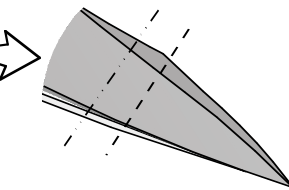

50. Lift up two layers and pleat symmetrically.

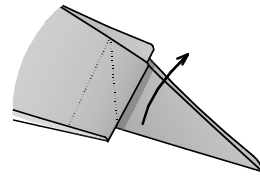

51. Swivel-fold the top layer up.

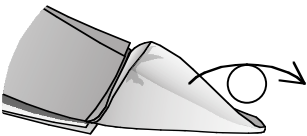

52. Turn the model over.

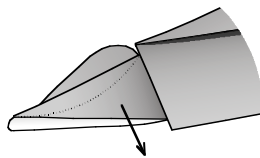

53. Pull down the top layer to form a cup.

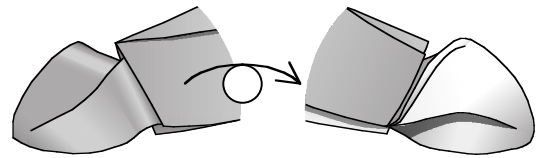

Finished hand.

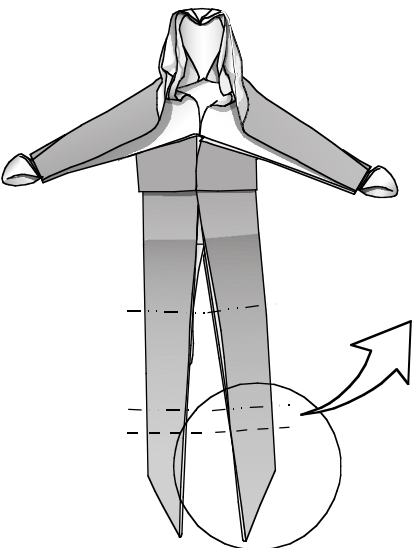

54. Crease. Do the following folds on both feet.

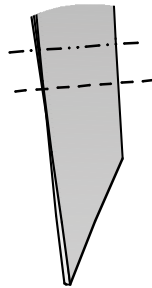

55. Pleat symmetrically



56. Swivel-fold the top layer (it will not lie flat).

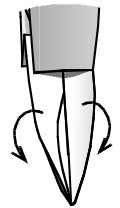

57. Make the foot convex.

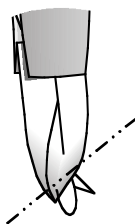

89. Mountain-fold the edge under.

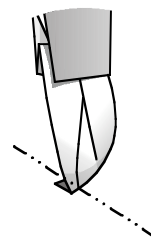

59. Mountain-fold the toe tip under.



Finished foot.



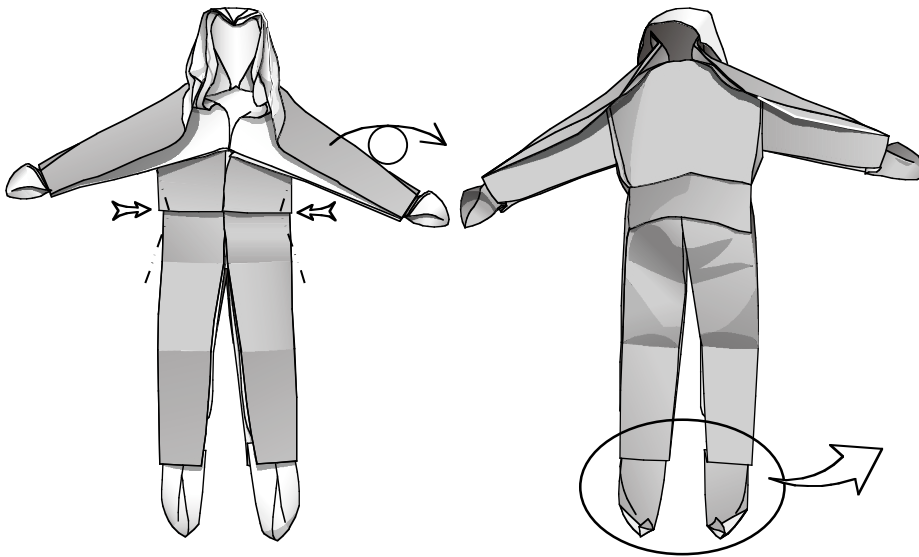

60. Inside reverse-fold edges to narrow the waist and shape the hips. Turn the model over.

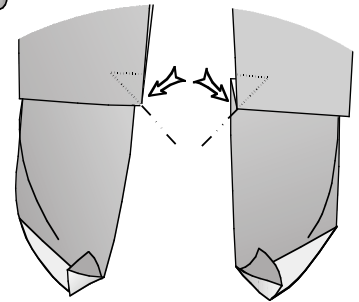

61. Inside reverse-fold corners of the pleat that is under the top layer of the leg.

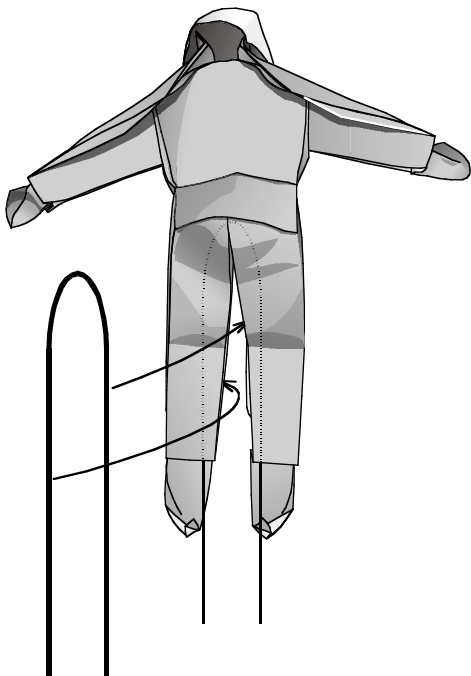

62. Insert a wire loop under two layers of the legs. Tape or glue it to an inner white layer.

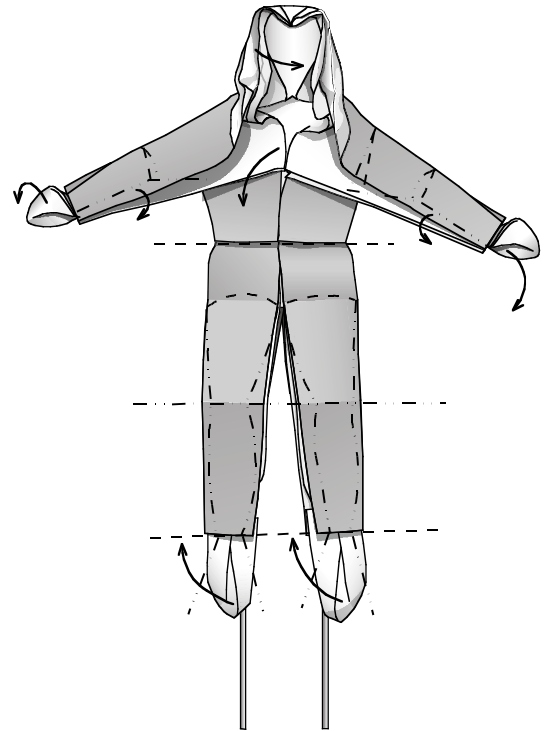

63. Shape the body to catch a wave. Turn the head, lower an arm with a crimp near the shoulder, round the legs and arms, turn a hand, bend the waist and legs. I stuff the body and limbs with cotton.

