

Caiman

Created / 2012

Difficulty / Intermediate

Time to fold: 30 minutes

R = 0.6 for length

Author's advice: It is not a good idea to go swimming after dark in the Amazonian tributaries. Just below the surface there might lurk a caiman, a South American alligator. Fold yours from a bi-colored square, white, yellow, or orange on one side for the eyes and teeth; and brown to black for the body.

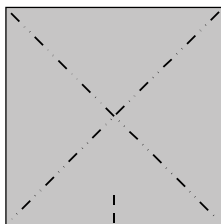
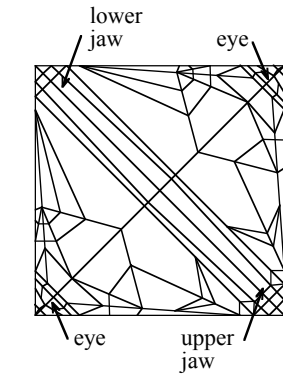
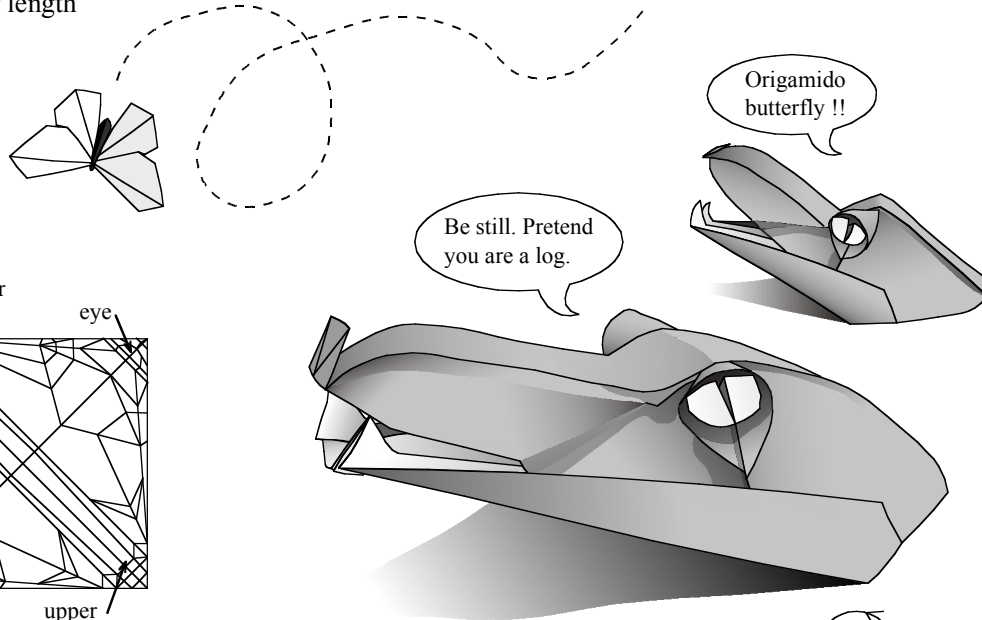

1. Mountain-crease diagonals and the midpoint of the bottom edge on the dark side of the square.

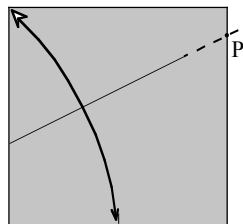

2. Place the top left corner on the bottom edge midpoint and crease the right side at point P.

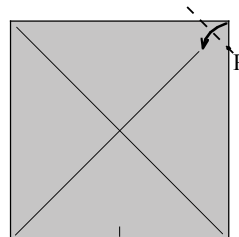

3. Valley-fold the top right corner to the upward diagonal through point P.

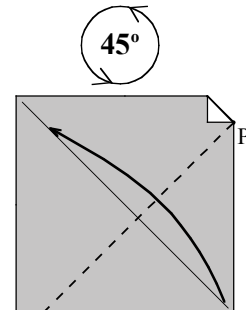

4. Valley-fold the bottom right corner to the downward diagonal through point P. Rotate the model 45 degrees counter-clockwise.

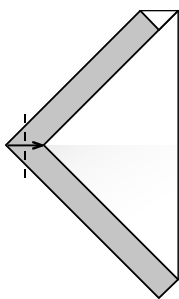

5. Valley-fold corner to corner.

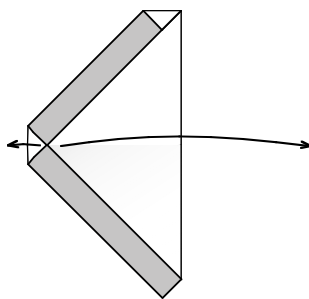

6. Unfold.

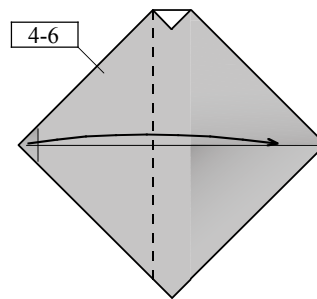

7. Repeat steps 4 to 6 on the other side without rotating.



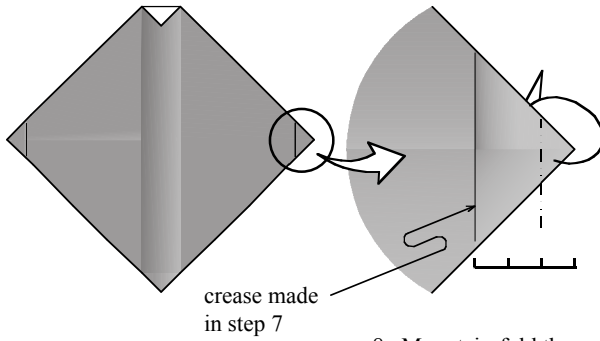

crease made in step 7

8. Mountain-fold the right corner behind.

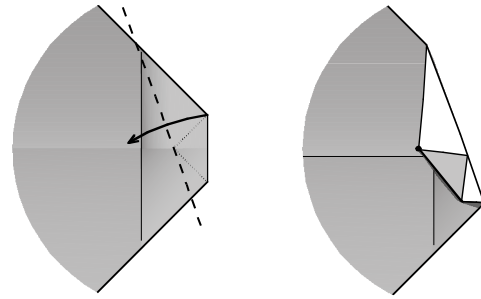

9. Valley-fold through the hidden corner's tip. The edge marked by the dot should be a little above the diagonal.

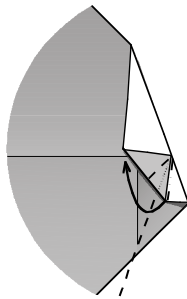

10. Swivel-fold the other corner of the small triangle to create a narrow eye slit.

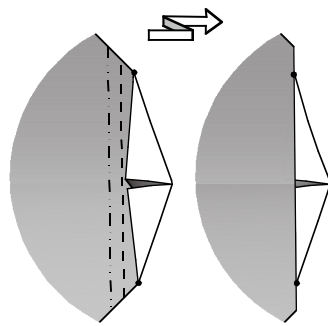

11. Pleat the eye so that the mountain fold lies on the dots.

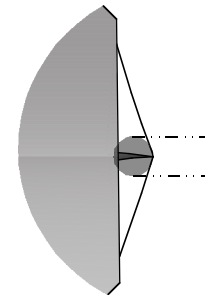

12. Mountain-crease the edge of the "eye" on either side of an imagined eyeball (shaded circle).

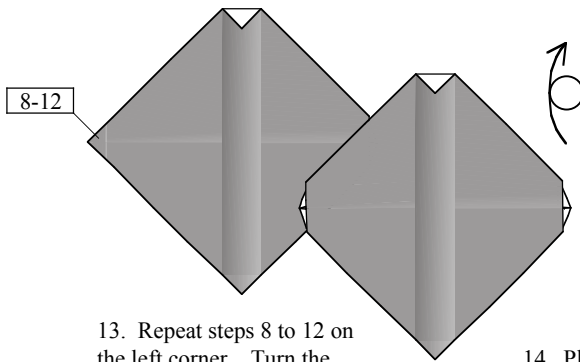

13. Repeat steps 8 to 12 on the left corner. Turn the model over top to bottom.

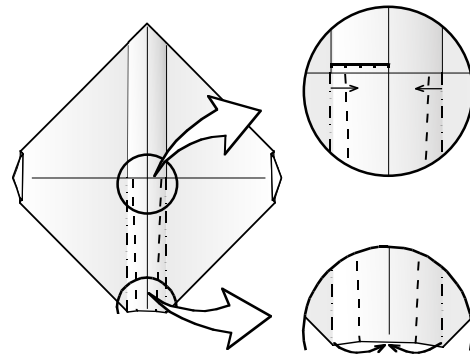

14. Pleat the bottom half of the model on angled valley folds. The model won't lie flat.

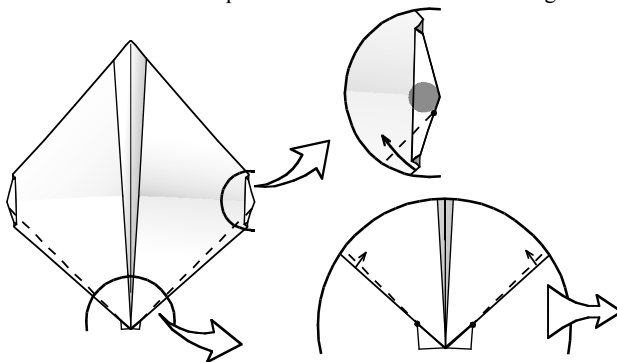

15. Valley-fold edges from creases from step 12 and 13 to the end of the lower jaw (dot pair).

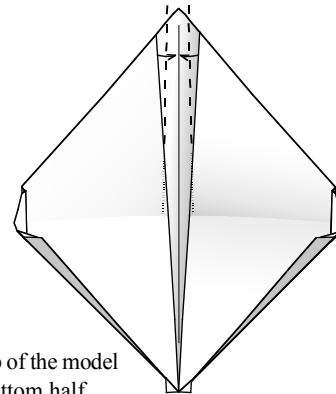

16. Pleat the top of the model to mirror the bottom half.



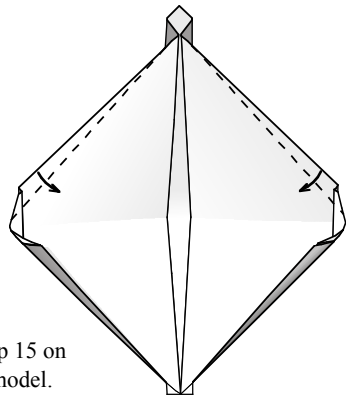

17. Repeat step 15 on the top of the model.

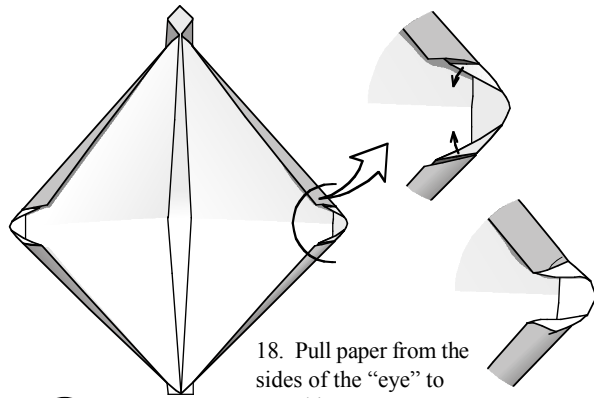

18. Pull paper from the sides of the "eye" to round it.

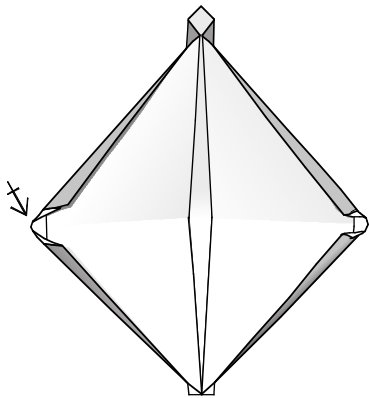

19. Repeat step 18 on the other eye.

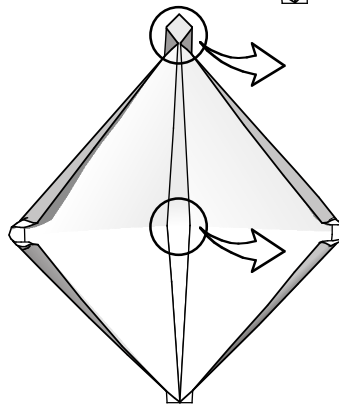

20. Valley-fold the top corner down. Dent edges at the midline.

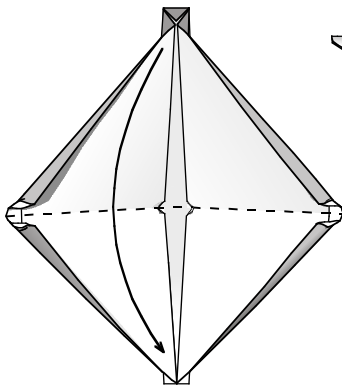
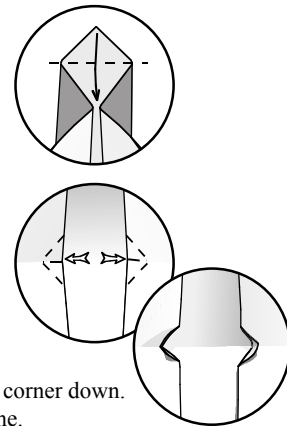

21. Valley-fold the model in half.

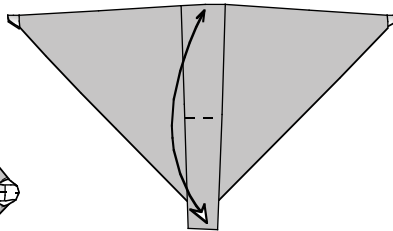

22. Mark the midpoint of the head with a crease.

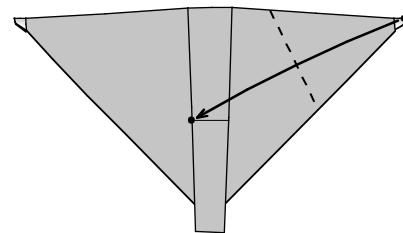

23. Valley-fold the top right corner to the left side of the head crease.

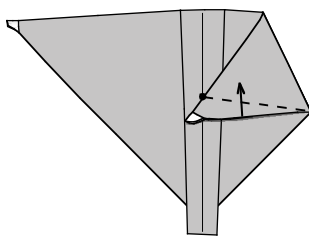

24. Valley-fold the eye flap up where its top edge touches the midline (dot).

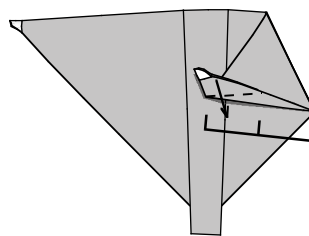

25. Valley-fold the eye flap down.

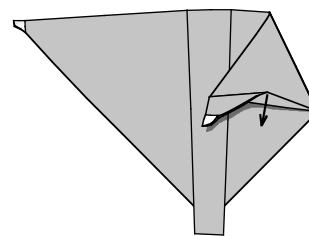

26. Unfold the last two steps.



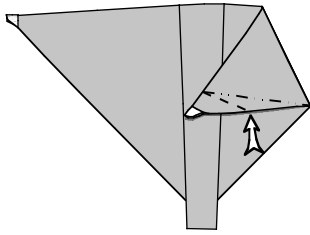

27. Crimp the flap symmetrically.

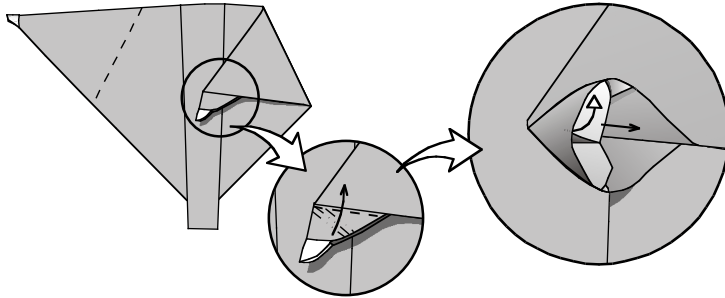

28. Squash-fold the eye flap into a cone shape.

29. Round the eye by pulling a bit of paper out of the pleat of step 11 at the site of the white arrow.

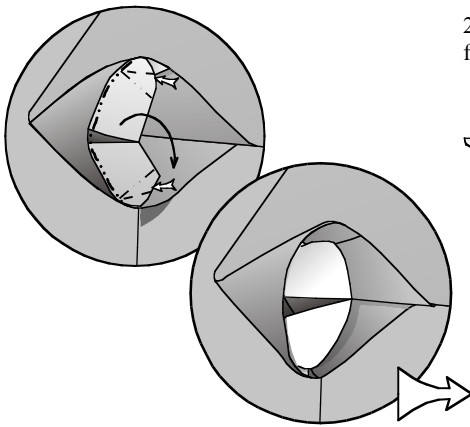

30. Crimp the sides of the eye to round it further. Mountain-fold it down to cover the cone's entrance.

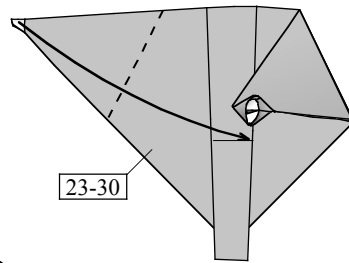

31. Repeat steps 23-30 on the left eye flap.

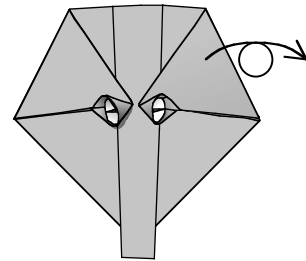

32. Turn the model over.

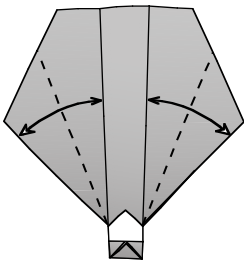

33. Valley-fold and unfold angle bisectors through all layers.

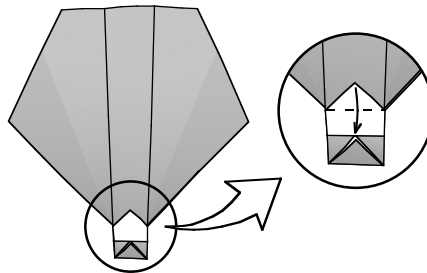

34. Fold the corner down.

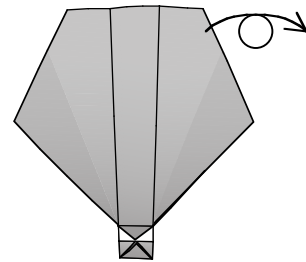

35. Turn the model over.

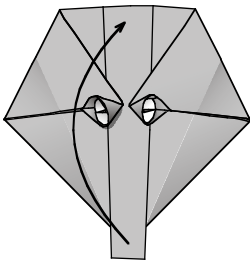

36. Lift up the top layer.

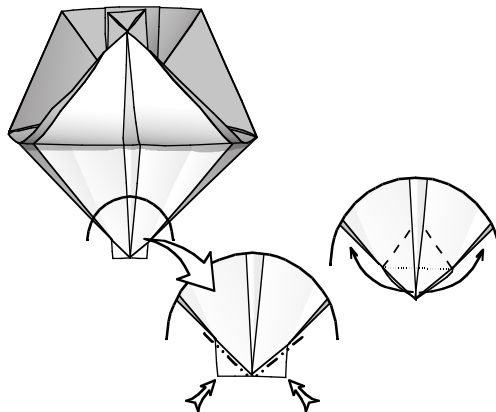

37. Inside reverse-fold corners. Swivel-fold two "teeth" to the side.

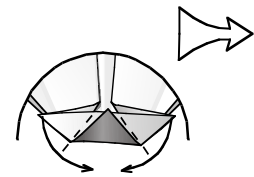

38. Valley-fold the teeth down.



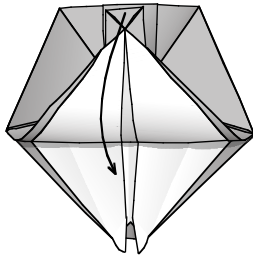

39. Put the upper layer back down.

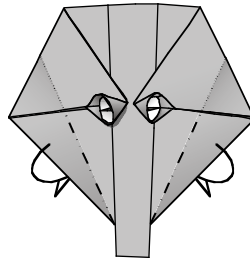

40. Mountain-fold one layer underneath.

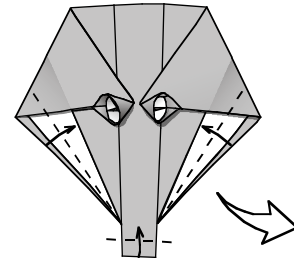

41. Valley-fold edges to edges (angle bisectors). Valley-fold the nose up.

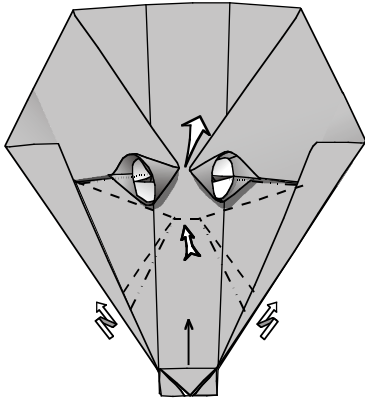

42. Crimp the upper jaw. Shove it back toward the eyes. The forehead will rise up.

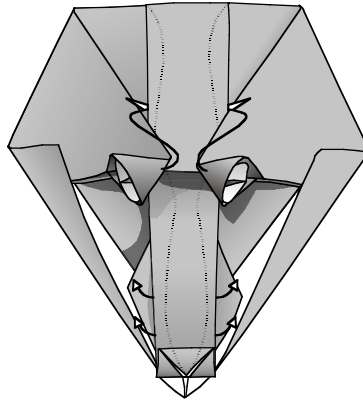

43. Release paper from the midline pleat to raise the forehead some more and make the upper jaw 3-D. X-ray lines show the result of the hidden pleat folds under the top layer. Tuck the eye cones under the pleat if you can.

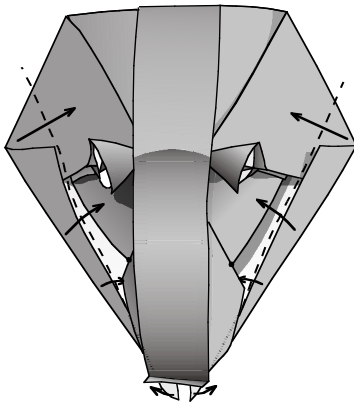

44. Valley-fold lower jaw sides up into the notch of the upper jaw (dots). Spread the teeth to the sides.

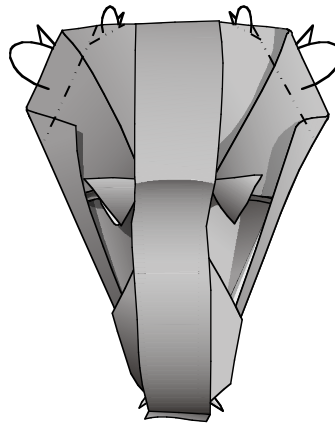

45. Round the back of the head with mountain folds.

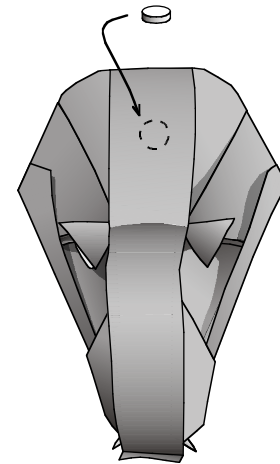

Optional: Put a magnet on the bottom layer inside the model to attach the caiman to a river or to your refrigerator.

