

Woman in a Burqa

Bernard Peyton
California, USA

Intermediate, copyright 2006

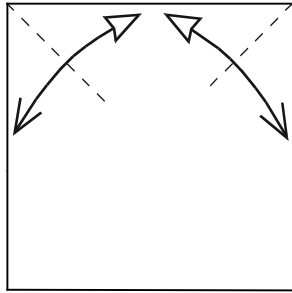

1. Use a bi-colored square, blue or black on one side, and white to light brown on the other side. Wet folding is suited for this model. Crease the diagonals at the top.

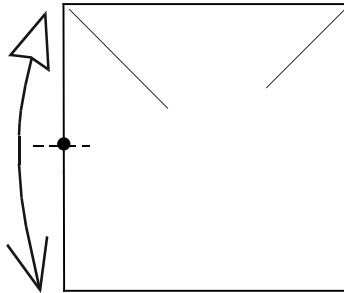

2. Crease the midpoint of the left edge.

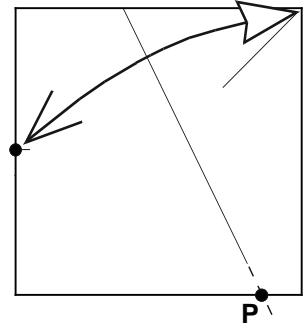

3. Bring the top right corner to the left edge midpoint and crease the bottom edge at point P.

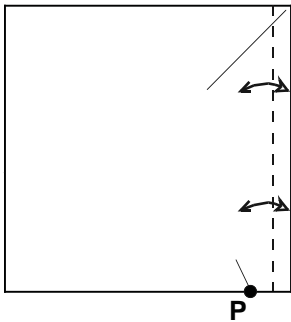

4. Fold-unfold the right side to point P.

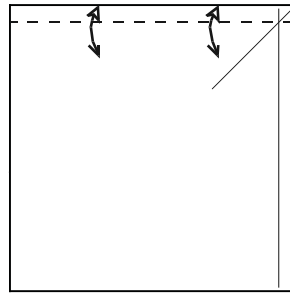

5. Fold-unfold the same amount of paper along the top edge.

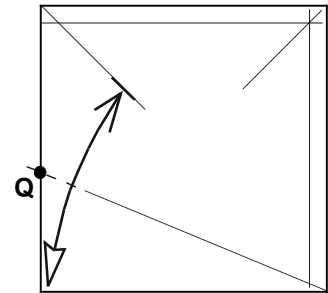

6. Kite fold the bottom left corner to the downward diagonal and pinch the left edge at point Q.

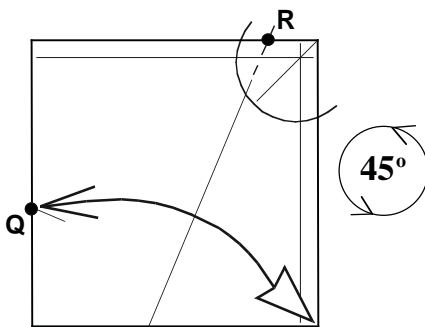

7. Bring the right bottom corner to point Q. Pinch the top edge at point R.

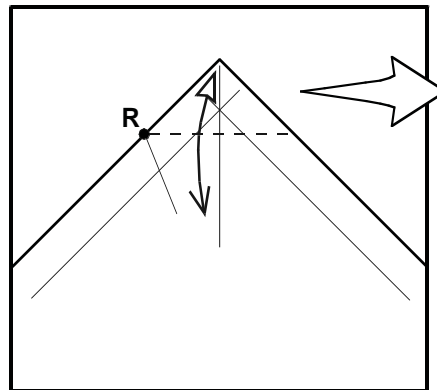

8. Fold-unfold the corner to the diagonal through point R.

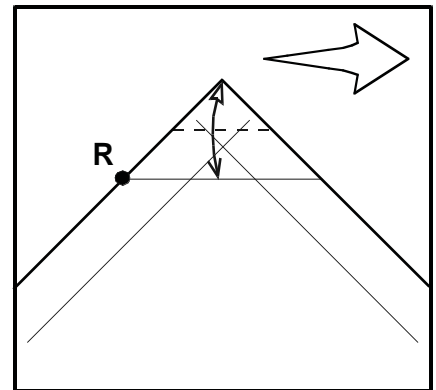

9. Fold-unfold the corner to the crease you just made.

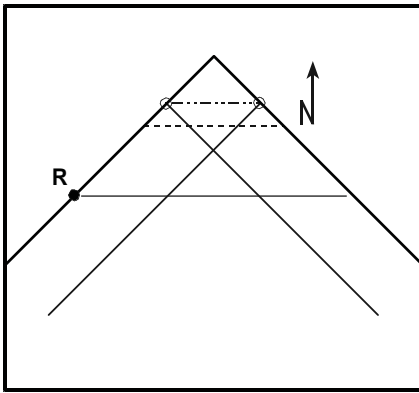

10. Pleat the corner by changing the fold of step 9 to a mountain fold. The valley fold above lies between the intersections of folds 4 and 5 with the paper edges.

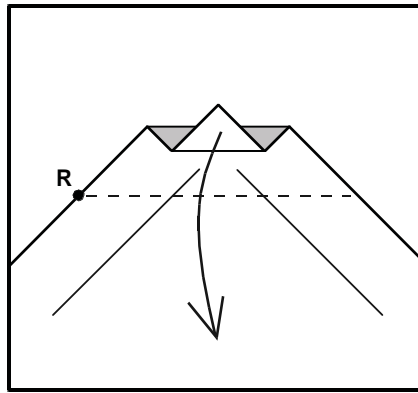

11. Valley fold the corner down on the crease of step 8.

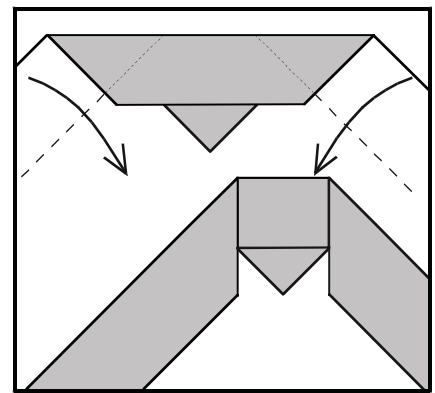

12. Valley fold edges on creases of steps 4 and 5.

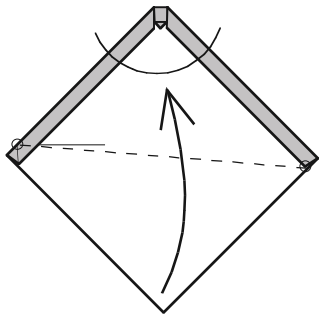

13. Valley fold the bottom half of the model up asymmetrically. The fold starts at the left edge where the diagonal of step 1 intersects it. The fold touches the tip of the folded over corner on the right side.

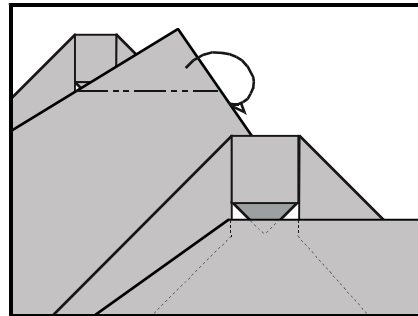

14. Mountain fold the corner parallel to the top edge of the darkened small triangle. X-ray lines indicate location of the paper edges underneath. Adjust the height of this fold to reveal two small triangular "eyes".

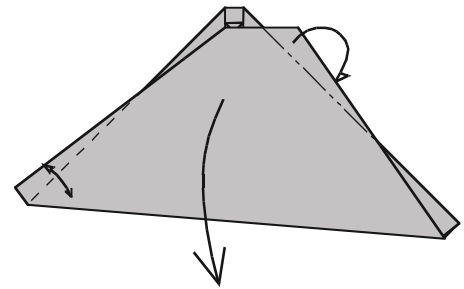

15. Mountain fold the right edge on a crease a bit lower than the edge of the layer behind it. Fold-unfold the left edge in a similar fashion and then fold the flap down.

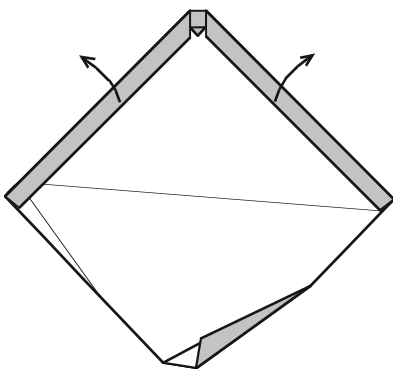

16. Unfold the edges.

Note: The previous folds allow the bottom half of the model to fit under the folded over edges of the top half.

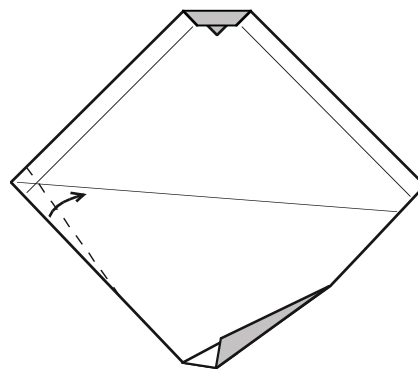

17. Valley fold the bottom edge of the left corner along the crease of step 15.

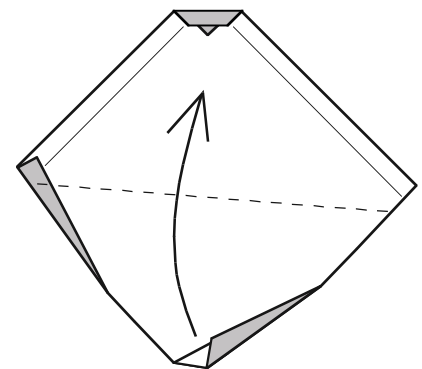

18. Fold the bottom half of the model up along the crease of step 13.

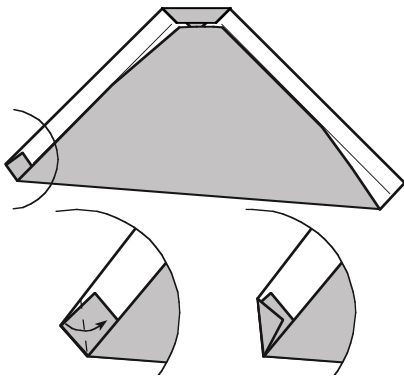

19. Valley fold along the diagonal crease of step 1.

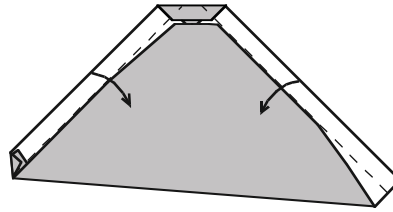

20. Refold the top edges. Adjust folds 15 and 17 if the top layer crinkles after this step. Your woman's eyes should look like the inset illustration of the next step.

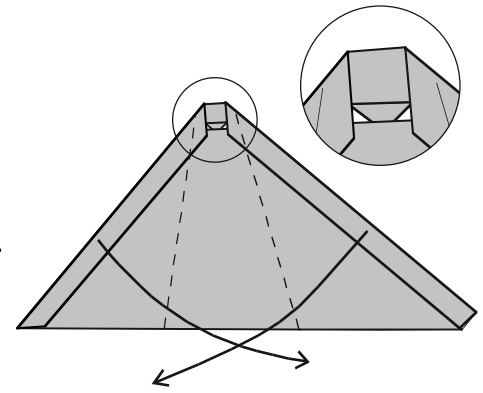

21. Cross the two sides so that their edges meet the crease of the opposing side. Don't crease sharply.

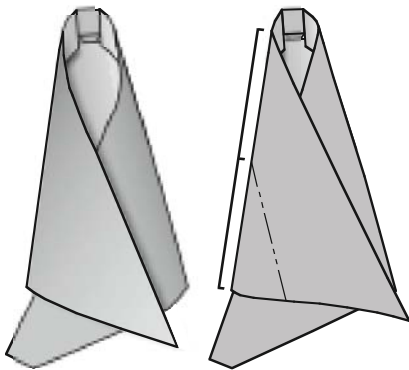

22. Mountain crease the left flap of the model on a line nearly parallel its edge.

Note: Make sure eyes are visible after crossing flaps.

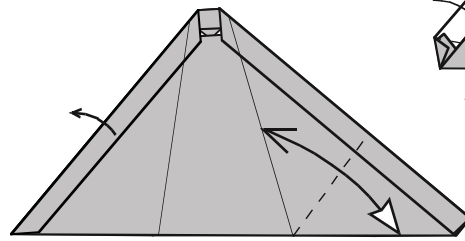

23. Unfold the left edge. Fold-unfold the right edge to a crease of the last step.

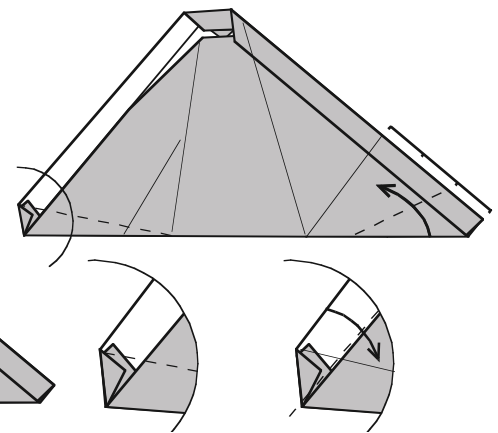

24. Crease the left side of the model as indicated and then fold down the left edge (step 5). Valley fold the right side up. The upper edge of the resultant flap is parallel to the crease of step 23.

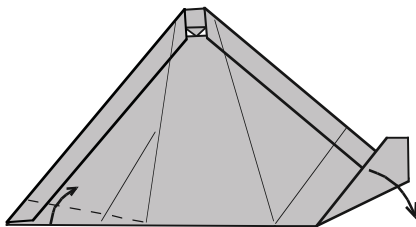

25. Valley fold the left bottom edge up on the crease just made.

Unfold the last step on the right side.

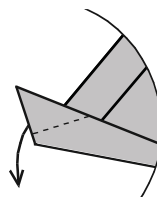

26. Fold the left tip down. The edges on the left side meet. Valley fold this "foot" assembly to the right. The bottom edges of this fold also lie along the same line.

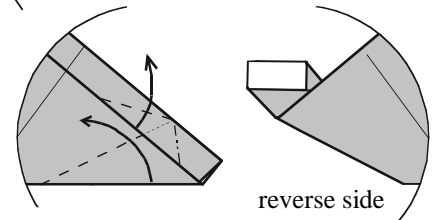
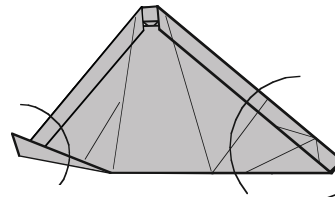

27. Swivel the paper's edge up as you refold the right side of the model. Adjust folds if necessary to make a rectangle of light paper on the reverse side of this flap.

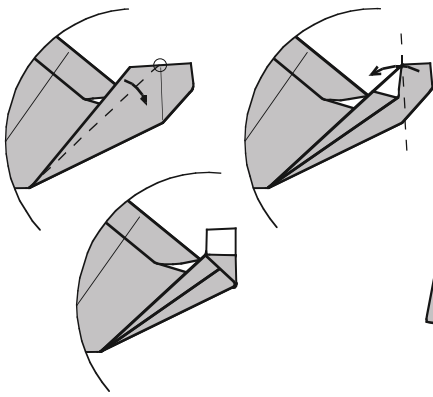

28. Narrow the flap with a valley fold. Fold the end of the flap to the left on an existing crease. This flap end will become a hand.

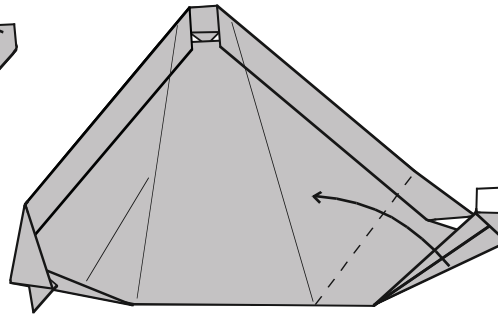

29. Fold the hand assembly up on the crease of step 23.

You are now ready for final shaping.

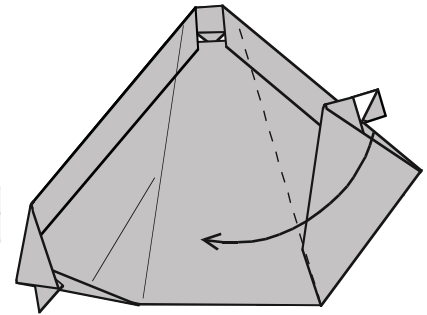

30. Fold the right side of the model past the center on the crease of step 21. Don't pinch it sharply. Curve the lower edge of this flap.

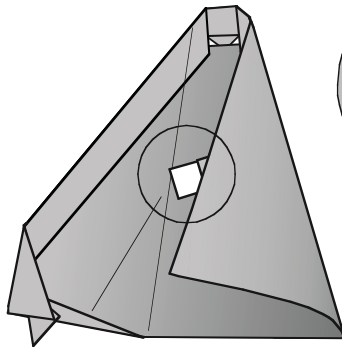

31. Shape the hand by folding corners behind, creating a thumb, and narrowing the wrist and curling fingers.

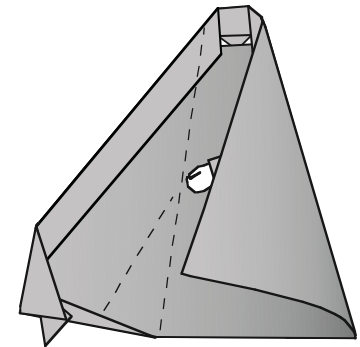
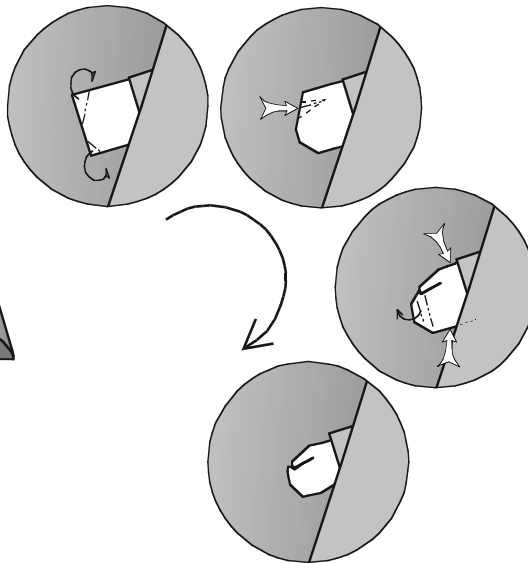

32. Fold the left side of the model under the right side with the hand. Round the contour of the model like a cone (see next diagram).

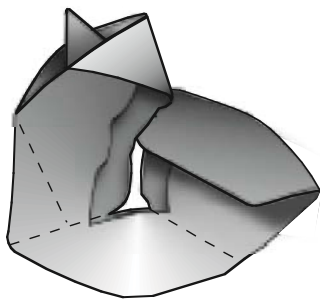

bottom view

33. Fold the foot up, shape the arms and wrist with curved valley folds, and dent the right side with a valley crease that angles down

